

**Tower Crane  
Grue à tour**

# Turmdrehkran 54 K

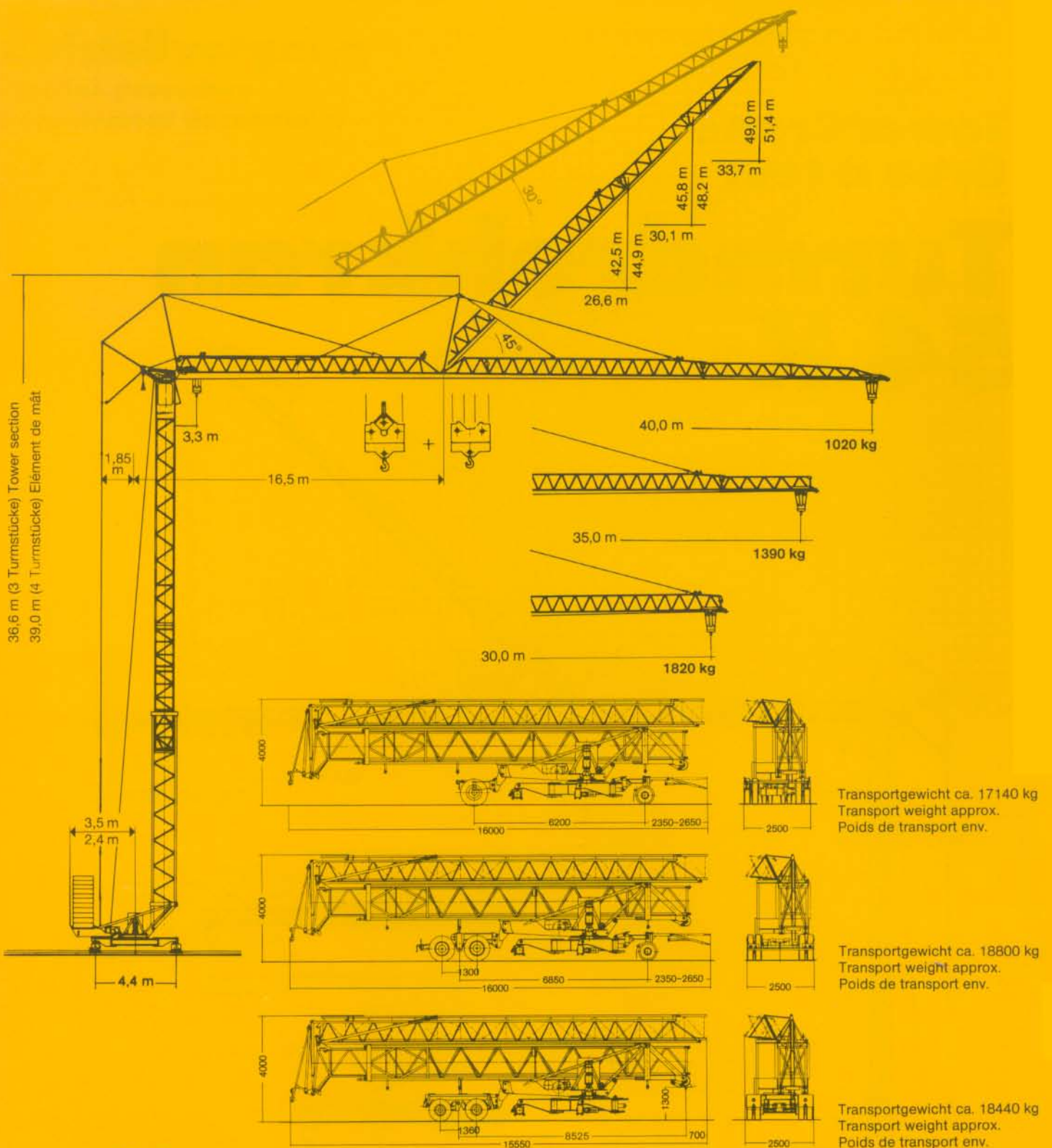

# LIEBHERR



## Gewicht Weight Poids

Max. Eckkraft in Betrieb Max. corner pressure in operation Réaction maxi. par angle en service	250 kN*
Max. Eckkraft außer Betrieb Max. corner pressure out of operation Réaction maxi. par angle hors service	220 kN*

Gegengewicht ca. Counter weight approx. Contrepoids env.	r = 3,5 m r = 2,4 m	20000 kg 27500 kg
Konstruktionsgewicht (max. Ausladung + Hakenhöhe) ca. Dead weight (max. radius + hook height) approx. Poids de la construction (max. portée + hauteur sous crochet) env.		16700 kg

\* Umrechnung der Einheiten für Kräfte 1 kp ≈ 10 N; 10 kN ≈ 1 Mp. / Conversion of the units for forces. / Conversion des unités des forces.

# 54 K

# Ausladung und Tragfähigkeit

## Radius and capacity / Portée et charge

Auslegerlänge Length of jib Longueur de flèche m	max. kg m/kg	m/kg																				
		20,0	21,0	22,0	23,0	24,0	25,0	26,0	27,0	28,0	29,0	30,0	31,0	32,0	33,0	34,0	35,0	36,0	37,0	38,0	39,0	40,0
40,0	3,3 - 21,8 2300	2300	2300	2270	2150	2040	1940	1850	1760	1690	1610	1545	1480	1430	1370	1320	1270	1230	1180	1140	1110	1070
35,0	3,3 - 24,0 2300	2300	2300	2300	2300	2300	2190	2090	2000	1910	1830	1750	1680	1610	1560	1500	1445					
30,0	3,3 - 25,3 2300	2300	2300	2300	2300	2300	2300	2230	2130	2040	1950	1870										

m	max. kg m/kg	m/kg																				
		13,0	14,0	15,0	16,0	17,0	18,0	19,0	20,0	21,0	22,0	23,0	24,0	26,0	28,0	30,0	32,0	34,0	35,0	36,0	38,0	40,0
40,0	3,3 - 20,8 2250 - 11,9 4500	4300	3910	3580	3300	3050	2840	2660	2490	2340	2210	2090	1980	1790	1630	1480	1370	1270	1220	1180	1090	1020
35,0	3,3 - 23,8 2250 - 13,1 4500	4500	4380	4020	3700	3430	3200	2990	2810	2640	2490	2360	2240	2020	1850	1690	1560	1440	1390			
30,0	3,3 - 25,5 2250 - 13,9 4500	4500	4500	4300	3960	3670	3420	3200	3010	2830	2670	2530	2400	2170	1980	1820						

m	max. kg m/kg	Auslegersteilstellung 30° Elevated jib 30° Flèche inclinée 30° m/kg																				
		16,0	17,0	18,0	19,0	20,0	21,0	22,0	23,0	24,0	25,0	26,3	27,0	28,0	29,0	30,0	30,6	31,0	32,0	33,0	34,0	34,9
40,0	3,1 - 19,2 2300 - 13,1 4500	2300	2300	2300	2300	2180	2050	1940	1830	1740	1650	1545	1490	1430	1360	1310	1270	1250	1200	1150	1110	1070
35,0	3,1 - 21,1 2300 - 13,1 4500	2300	2300	2300	2300	2300	2300	2180	2070	1960	1860	1750	1690	1620	1550	1480	1445					
30,0	3,1 - 22,2 2300 - 13,1 4500	2300	2300	2300	2300	2300	2300	2300	2210	2090	1990	1870										

## Geschwindigkeiten Speeds / Vitesses

	U/min 0 - 0,8 sl./min tr./min	3,0 kW
	20,0 / 40,0 m/min	1,5 / 2,2 kW
	25,0 m/min	2 x 1,5 kW
	0-45° ca. 60 sec.	3,0 kW

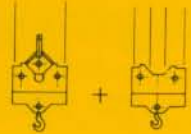
Hubwerk Hoist unit Mécanisme de levage	Stufe Step Cran	kg	m/min
15,0 kW 	1	2300	6,0
	2	2300	27,0
	3	1600	50,0
	1	2250 4500	6,0 3,0
	2	2250 4500	27,0 13,5
	3	1600 3200	50,0 25,0

Leitungsquerschnitt bei 380 V  
Cross section of cable  
Section de câble à  
Betriebsspannung 380 V  
Operating voltage  
Tension de service

bis 99,0m  
up to  
jusqu'à  
Frequenz 50 Hz  
Frequency  
Fréquence

Anschlußwert 28,0 kVA  
Power requirement  
Puissance requise

# Technische Daten - Technical data Caractéristiques techniques

# Aufstellvorgang

Erection procedure

Déroulement de montage

Ballastierausladung 5,0 m

Ballasting radius 5,0 m

Portée pour dispositif de lestage 5,0 m

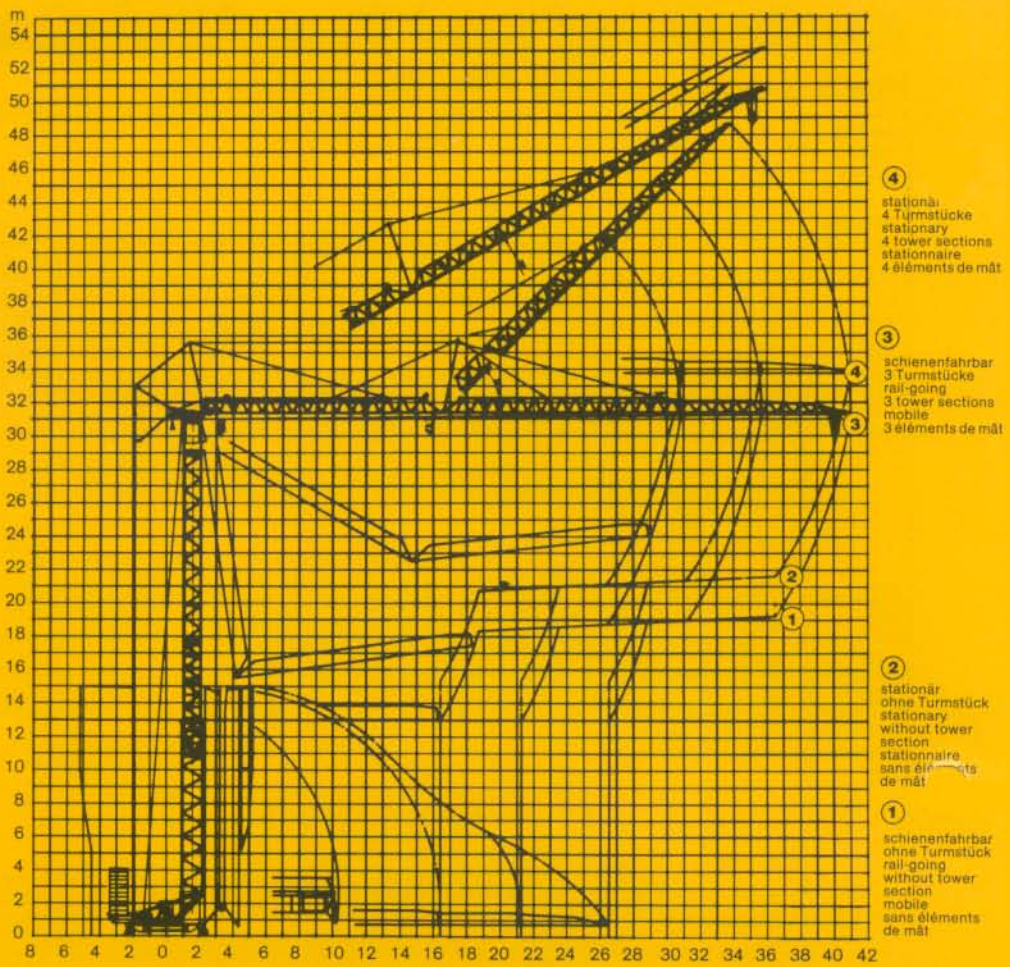

# Kolli-Liste

Packing List

Liste de colisage

Pos. Item Rep.	Anz. Qty. Qty.			L (m)	B (m)	H (m)	kg
1	3	Turmstück (ohne Turmauflage) Tower section without tower support Élément de mât sans support de mât		2,50	1,10	1,10	450
2	1	Turmstück (mit Turmauflage) Tower section with tower support Élément de mât avec support de mât		2,50	1,10	1,10	550
3	1	Ausleger-Verlängerung 30,0 m – 35,0 m Jib extension Rallonge de la flèche		5,00	1,02	0,80	185
4	1	Ausleger-Verlängerung 35,0 m – 40,0 m Jib extension Rallonge de la flèche		5,10	1,02	0,70	130
5	1	Transportachse vorne Tra 100 KY 1 Road transport axle front Essieux de transport avant		3,00	1,13	0,97	680
6	1	Transportachse hinten Tra 120 GY 1 Road transport axle behind Essieux de transport arrière		1,90	2,50	1,05	1200
7	1	Transportachse Tra 200 GZ 3 Road transport axle Essieux de transport		3,10	2,50	1,10	2500
8	1	Kiste mit Seilen und Kleinteilen Case with ropes and small parts Caisse avec câbles et pièces détachées		1,00	0,80	1,00	450

Datenblatt Nr. 120 P – 2427 FEM (Section 1) – Gruppe 3 • 04.94

Data sheet

Feuille de caractéristiques

Konstruktionsänderungen vorbehalten!

Subject to alterations!

Sous réserves de modifications!

Printed in Germany

Nehmen Sie Kontakt auf mit  
Contact

Mettez-vous en rapport avec

LIEBHERR-WERK BIBERACH GMBH, Postfach 1663, D-88396 Biberach an der Riß

☎ (07351) 41-0, Fax (07351) 4 1225, Tx 71 802